

ARMADIETTI FITNESS – PISCINE – SPOGLIATOI IN GENERE

I più avanzati orientamenti della progettazione di arredi destinati agli spogliatoi suggeriscono soluzioni condizionate da tre obiettivi primari: **la durata, il design e l'igiene.**

Gli armadietti serie K utilizzano senza risparmio materiali di altissima qualità alluminio anodizzato, acciaio inox, laminato massello e nylon..

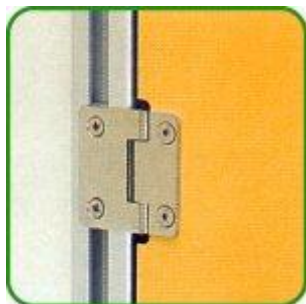

Acciaio inox
per cerniere
pedini
regolabili e
viterie.

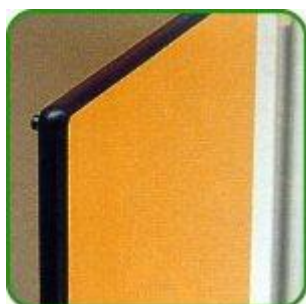

**Laminato
massello**
da mm.14 per
le ante, da
mm.8 per i
ripiani, da
mm.6 per i
fianchi e da
mm.4 per il
fondo.



**Alluminio
anodizzato**
un forte
spessore (2-3
mm.) per i
profili di
sostegno e per
i portaripiani .

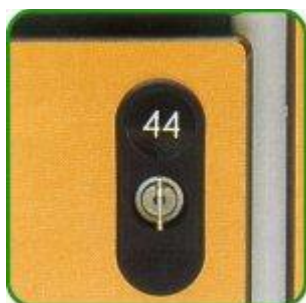

Nylon
per le serrature
e le finiture.



Semplicità e linearità; antine in un solo pezzo in laminato, nessun elemento d'assemblaggio in vista; dominio del colore; i profili di alluminio sono visibili solo ad antina aperta .



La forma stessa dell'antina, l'assenza di asperità superficiali e di recessi, i ripiani tenuti staccati dalle pareti, le speciali fessure, consentono una facile pulizia ed una elevata aerazione.

- **Struttura**
pannelli di laminato massello ad alto spessore; mm.6 per i fianchi, mm.4 per il fondo, mm.8 per i ripiani terminali; profili di alluminio anodizzato 15/100 di mm.
- **Ante**
in stratificato massello da 14mm. di spessore; bordatura perimetrale a sezione semicircolare con spigoli arrotondati; cerniere in acciaio inox.
- **Silenziatori**
in materiale plastico morbido.
- **Serratura**
in lega di alluminio ed ottone nichelato con scatola, finitura e catenaccio in nylon.
- **Ripiani intermedi**
in stratificato massello da mm.8 di spessore, con supporti regolabili in alluminio anodizzato.

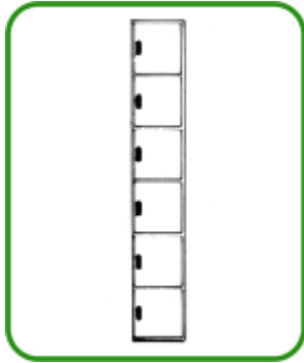

h. 30 cm.

cm. 30 x 50 x 30 (h)

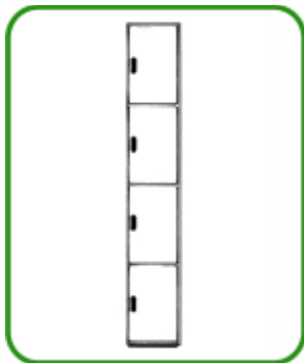

h. 45 cm.

cm. 30 x 50 x 45 (h)

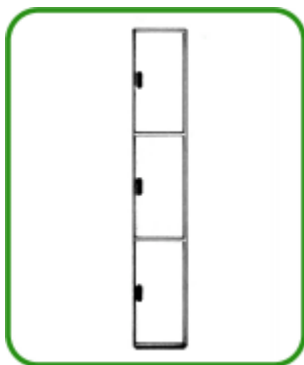

h. 60 cm.

cm. 30 x 50 x 60 (h)

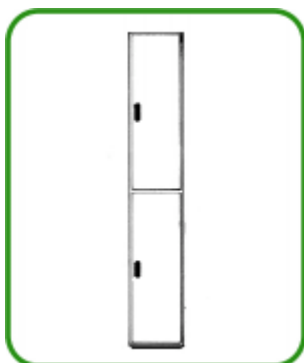

h. 90 cm.

cm. 30 x 50 x 90 (h)

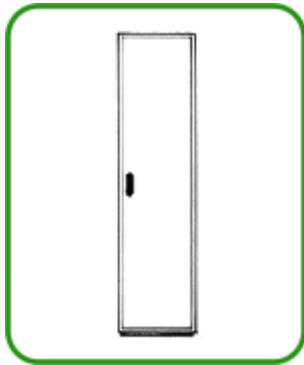

h. 120 cm.

cm. 30 x 50 x 120 (h)

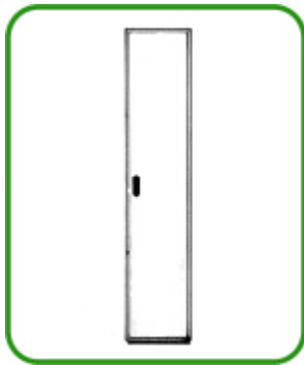

h. 150 cm.

cm. 30 x 50 x 150 (h)

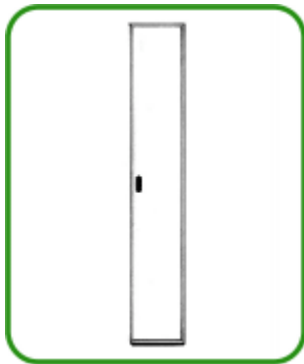

h. 180 cm.

cm. 30 x 50 x 180 (h)

TIPOLOGIA ARMADIETTI A L



Per ottimizzare lo sfruttamento dello spazio é prevista questa speciale tipologia di armadietti che rispettano la volumetria occupata da due vani sovrapposti da cm.90 di altezza consente di creare un vano verticale superiore a cm.90.

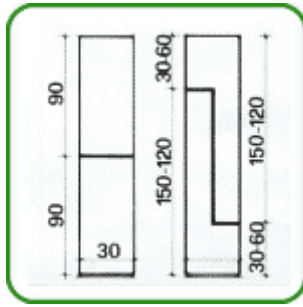

Ciò si ottiene dividendo lo spazio disponibile da 30x50x180(h) con un elemento a forma di Z. Il risultato è illustrato sul disegno che mostra vani da cm.120-150 di altezza.

- **Struttura, ante, silenziatori, serrature** come [modelli precedenti](#).

- **Ripiani** in stratificato massello da mm.14 a forma di Z vincolato ai montanti speciali giunti; finitura arrotondata e smussata.

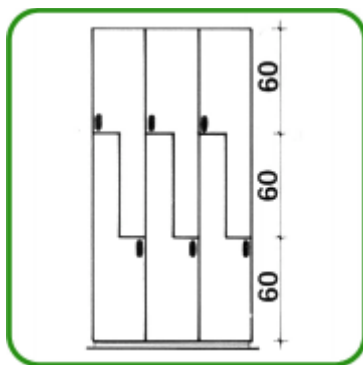
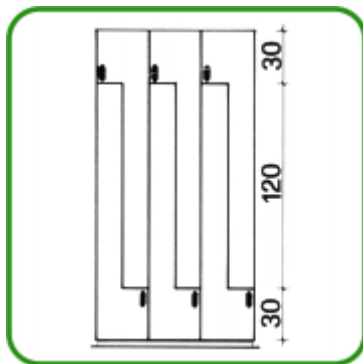

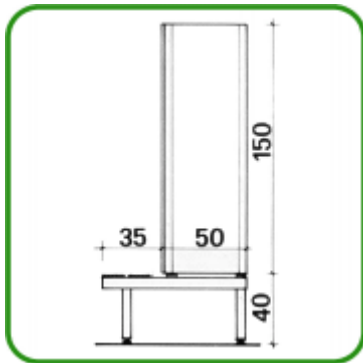
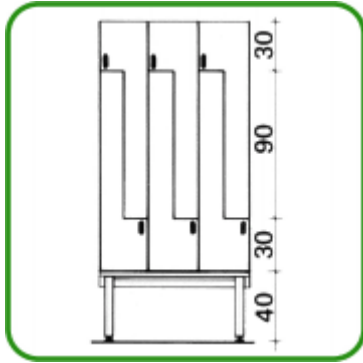

ACCESSORI:



Numerazione anta



Numerazione chiave con braccialetto MARK

Numerazione chiave con porta chiave CLIPS



Rialzo da terra



Limitatore di rotazione dell'anta



Gancio porta-abiti



Serratura digitale a tastiera



Gancio porta-abiti



Gancio multiplo

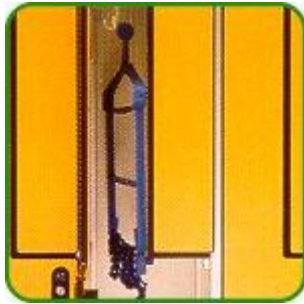

Appendiabito
appendiabito mod. CANGURO/A,B,C,D.
Vedere sezione



Serratura a gettone
Dotabile anche di gettoniera
Vedere anche sezione

GAMMA COLORI



0001
Bianco



0020
Bianco industriale



0203
Bianco ghiaccio



0010
Bianco azzurro



0264
Azzurro polare



0244
Porcellana



0204
Magnolia



0218
Beige



0200
Avorio



0205
Champagne



0237
Creta



0530
Giallo miele



0201
Sabbia



0536
Beige Isabella



0534
Bruno antilope



0637

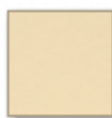

0256

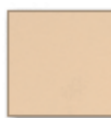

0648



0531



0573

Giallino

Giallo pastello

Giallo Murano

Giallo pulcino

Giallo primula

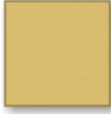

0647
Giallo Bisanzio



0670
Giallo Altamira



0661
Giallo gallo



0564
Giallo mais



0523
Giallo Colorado

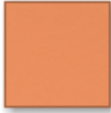

0682
Arancio



0543
Terracotta

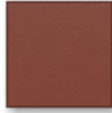

0542
Rosso tegola

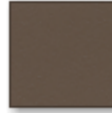

0559
Nocciola



0553
Cioccolato



0639
Rosa cammeo



0535
Rosa baby



0672
Rosa viennese



0202
Rosa antico



0649
Rosa beat



0610
Bruno egizio



0640
Rosa decò



0609
Rosa pop

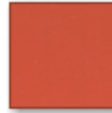

0500
Aragosta

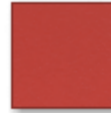

0561
Rosso devil



0638
Rosso fragola

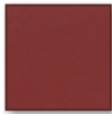

0571
Rosso oriente



0654
Terra Siena



0594
Fucsia



0511
Vinaccia



0206
Celeste pastello



0641
Crocus



0606
Lilla



0605
Glicine



0538
Amaranzo



0607
Lavanda



0569
Blu Valencia



0566
Blu Caraibi



0593
Blu Faenza



0608
Blu manto



0215
Blu acciaio



0619
Blu artico



0257
Blu Nassau



0659
Blu tropicale

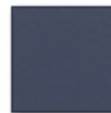

0673
Blu violetto



0665
Glicine



0248
Verde inglese



0614
Verdino



0651
Verde York



0664
Verde francese



Nota: i colori sopra visualizzati sono indicativi; l'esatta tonalità può essere esaminata richiedendo la relativa campionatura.

ALTRO MODELLO SEMPRE SIMILE CON MATERIALE ANTE DIVERSO

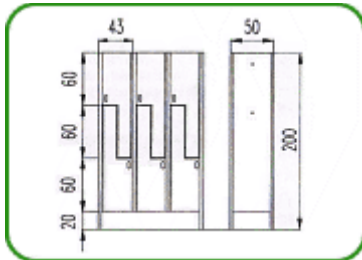
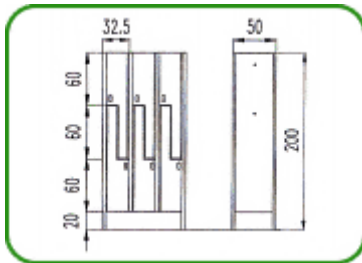

Numerazione anta



Serratura a lucchetto

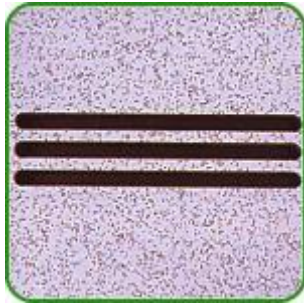

Triplice fresatura sull'anta



Ripiano interno

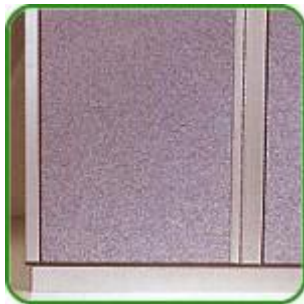

Zoccolo in alluminio anodizzato



Appendiabito



Serratura digitale a tastiera



serratura a gettone o a moneta



Kass/x-cassetta porta gettoni in acciaio inox



Gancio porta-abiti